

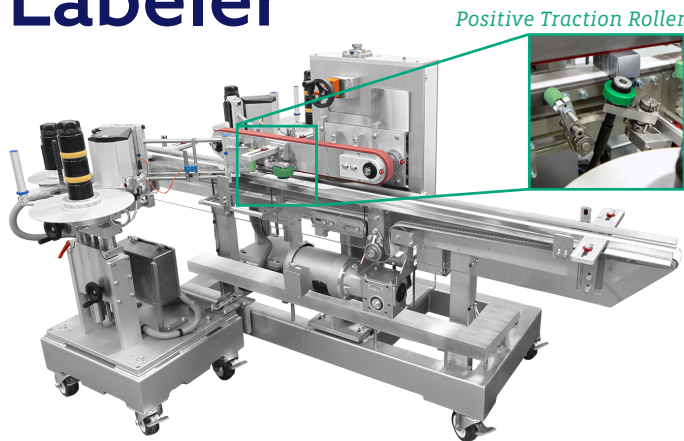

TEL10 Tamper Evident Labeler



Carton Range*	Length	Width	Depth
Minimum	3/4" 19 mm	1" 25.4 mm	1.5" 38.1 mm
Maximum	12" 304.8 mm	4" 101.6 mm	7" 177.8 mm
Label Range	Length	Width	
Minimum	.2" 5 mm	.2" 5 mm	
Maximum	8" 203.2 mm	3.15" 80 mm	
Roll Size: 11.8" w/ 3" core center			

*Larger Ranges Available

FEATURES AND BENEFITS

- Positive traction roller eliminates skewing during label folding
- Robust, compact design
- Quick-disconnect labeling heads
- Fast, accurate changeover
- Automatic changeover option available
- Low maintenance
- User-friendly
- Speeds up to 400 cartons per minute

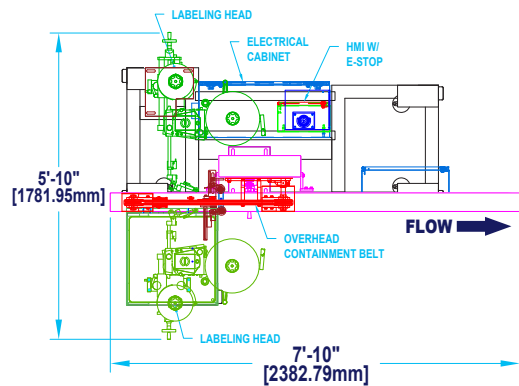

Standard Range Floorplan

- Straight or reverse tuck cartons
- Servo-driven labeling head
- Low level sensor for label roll



SERPA™

TEL10 TAMPER EVIDENT LABELER

STRAIGHT TUCK

REVERSE TUCK

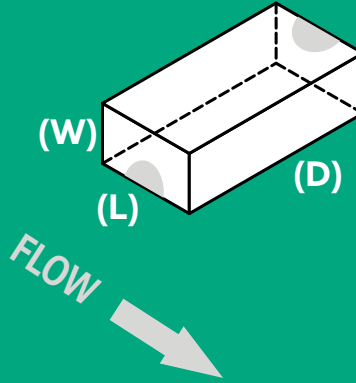
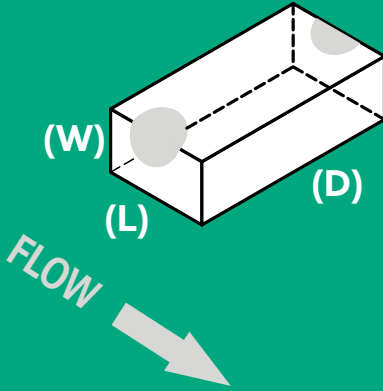

READY TO INTEGRATE WITH

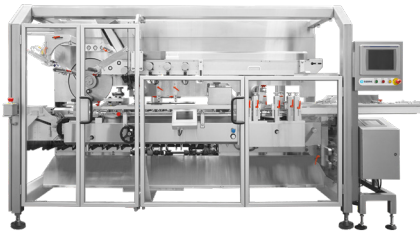

CARTONER



HIGH SPEED INSERT FEEDING SYSTEM

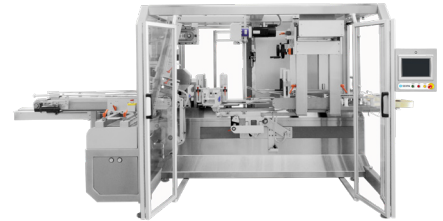

CASE PACKER

ABOUT SERPA

Founded in 1985, Serpa designs and manufactures cartoners, sleeves, case & tray packers, robotic palletizers, and auxiliary packaging equipment for the pharmaceutical, medical device, nutraceutical, food, beverage, personal care, cosmetic, household, and industrial markets. A ProMach brand since 2021.

PHONE
559.651.2339

EMAIL
serpa.info@promachbuilt.com

WEB
serpapakaging.com

LOCATION
7020 W Sunnyview Ave, Visalia, California, USA